

# SERIE 100 Porta a battente

SERIES 100 The folding door with leaf

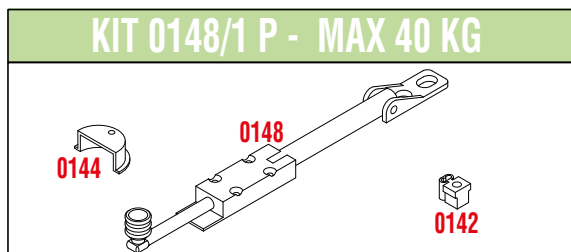

Sistemi scorrevoli per porte / Sliding systems for interior doors

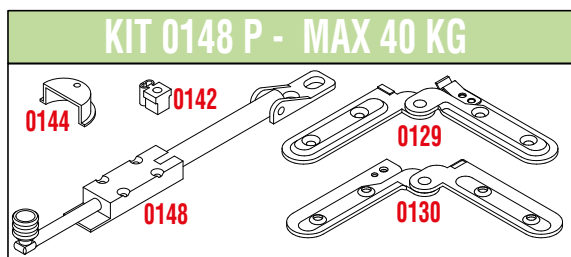

## Legenda KIT / Kit Legend

<b>0129</b>	Cerniera con molla per porta spessore 40 mm. <i>Hinge with spring for door thickness 40 mm.</i>
<b>0130</b>	Cerniera senza molla per porta spessore 40 mm. <i>Hinge without spring for door thickness 40 mm.</i>
<b>0148</b>	Guida con braccio telescopico <i>Guide with telescopic arm</i>
<b>0142</b>	Fermo superiore <i>Stopper</i>
<b>0144</b>	Sede per cerniera dia. 24 mm <i>Hinge seat 24 mm dia.</i>

## Legenda altri componenti Legend other items

<b>0140</b>		Profilo alluminio superiore <i>Upper aluminium profile</i>
<b>0149Z</b>		Battuta di fine corsa <i>End-of-run plug</i>

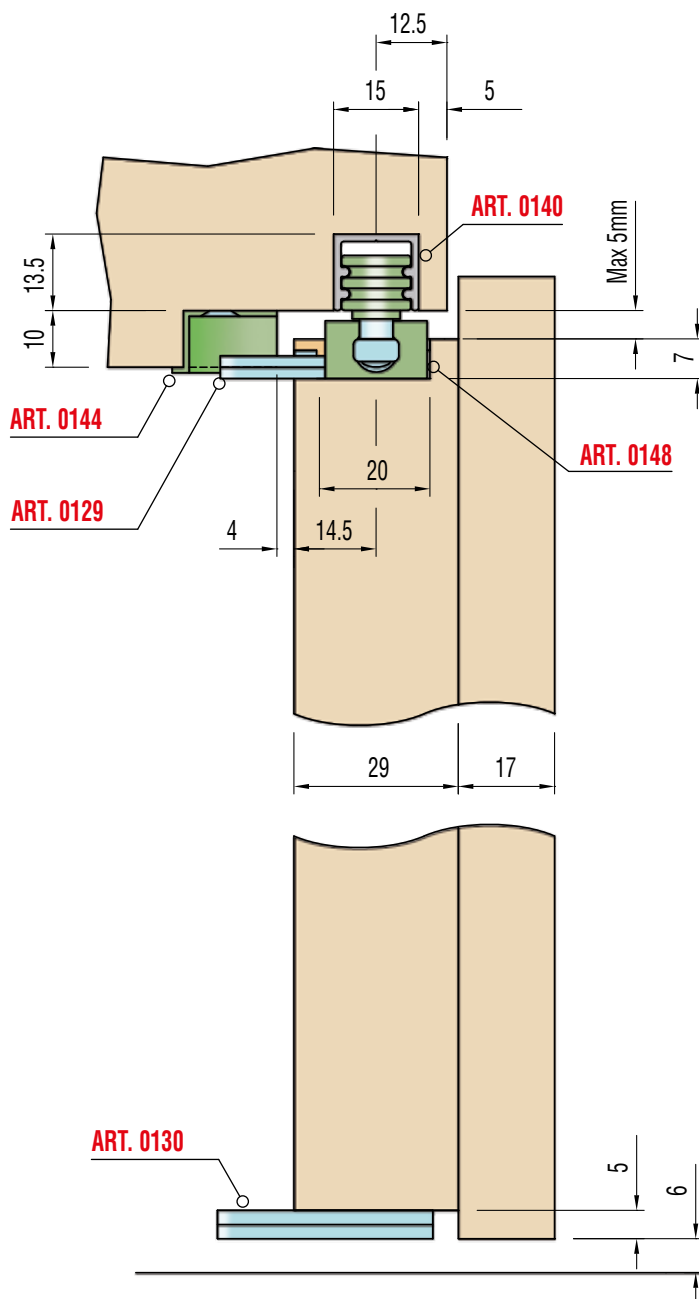

## Schema foratura per art. 0144 / Doors drilling for art. 0144

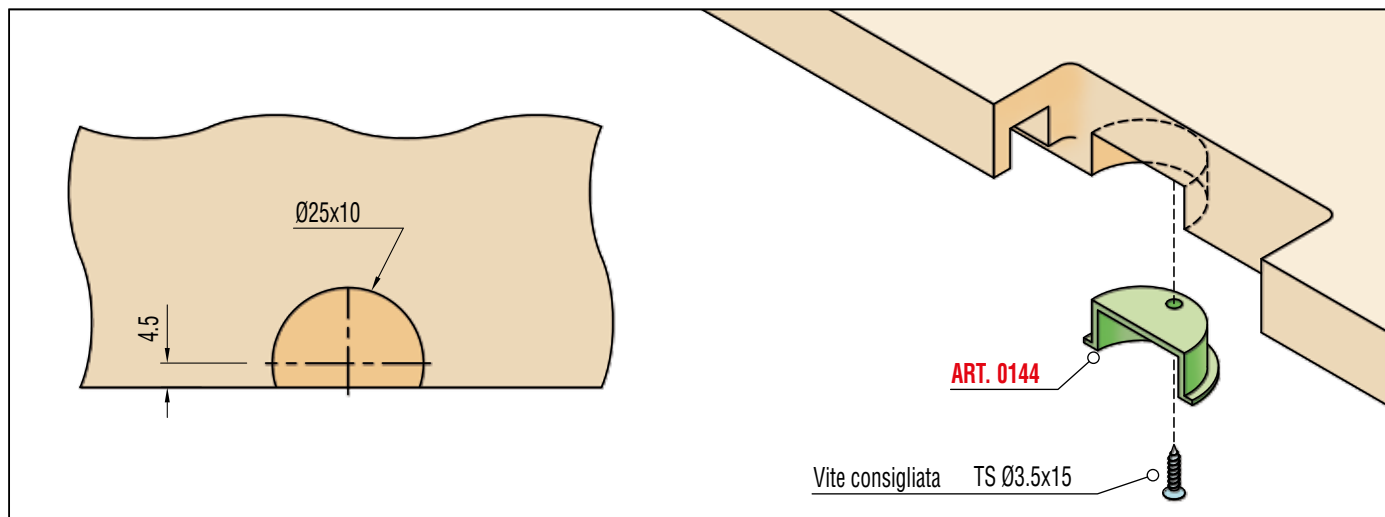



## Porta pieghevole con ante simmetriche / The folding door with symmetrical panels

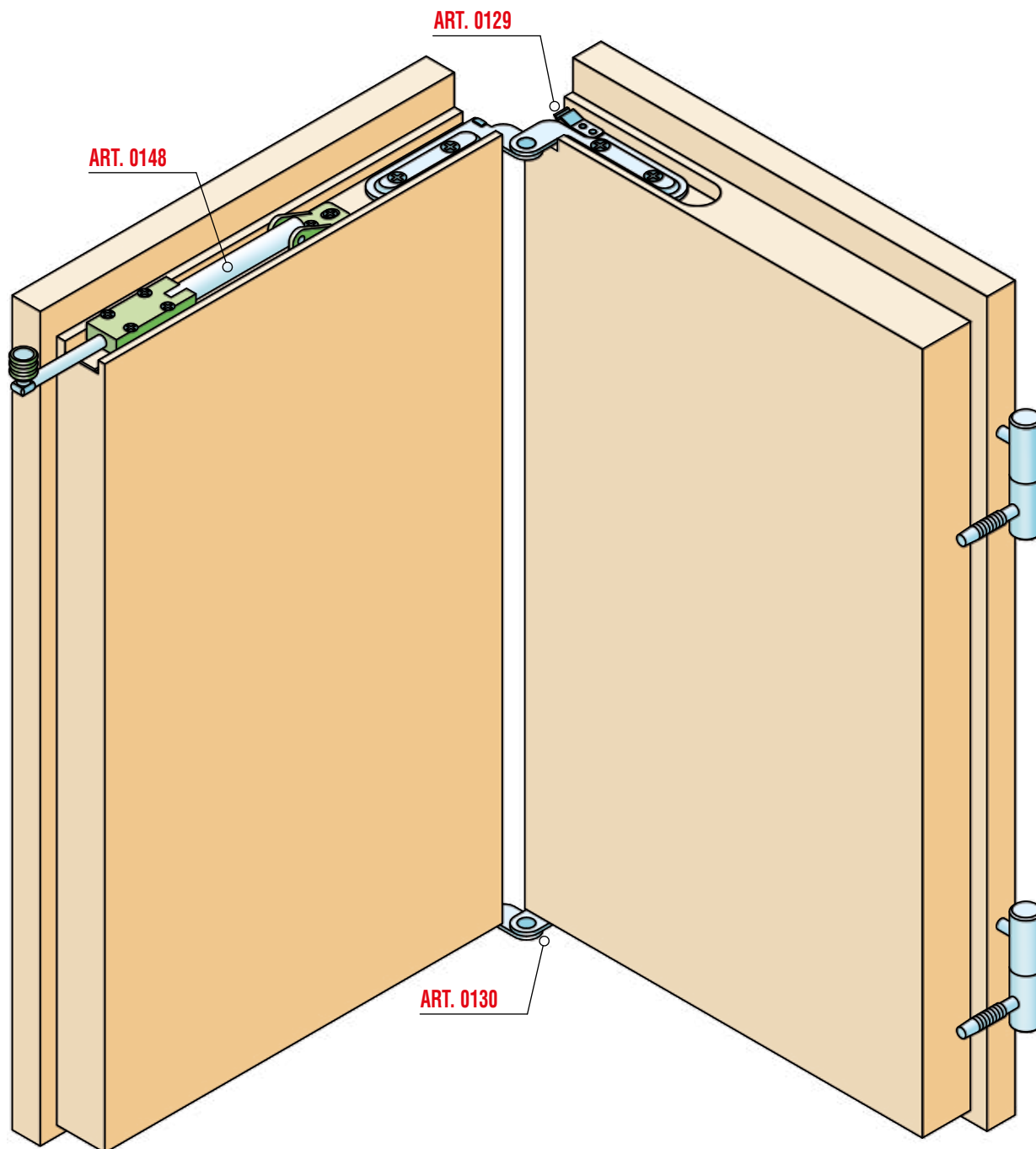

# SERIE 100 Porta a battente

SERIES 100 The folding door with leaf



Sistemi scorrevoli per porte / Sliding systems for interior doors

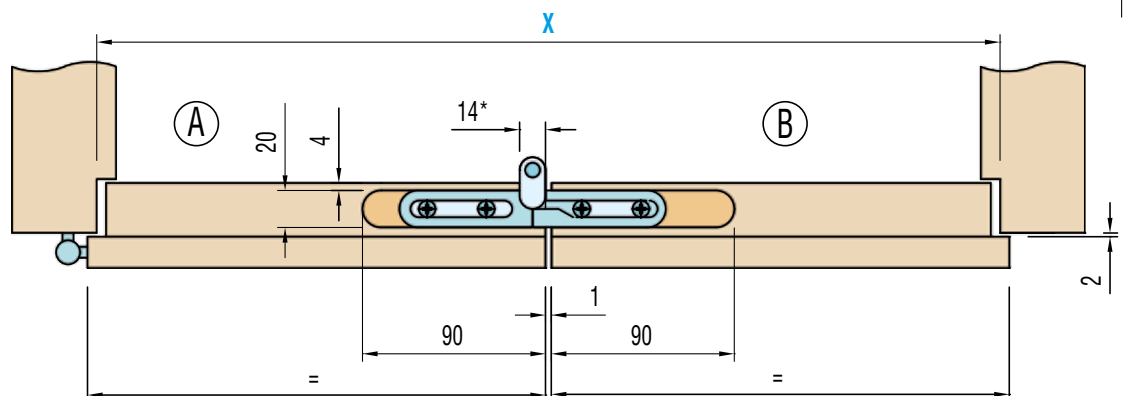
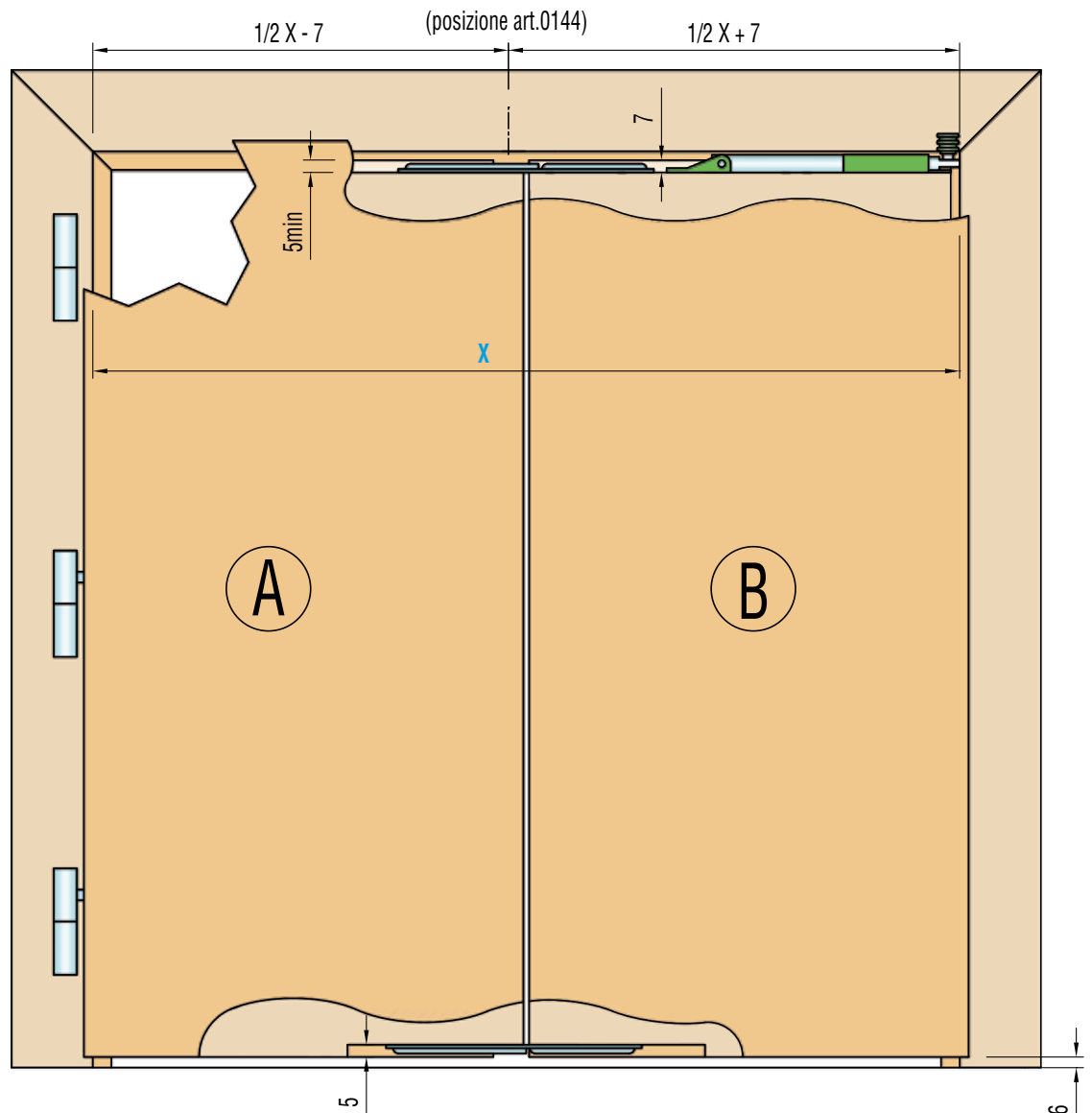
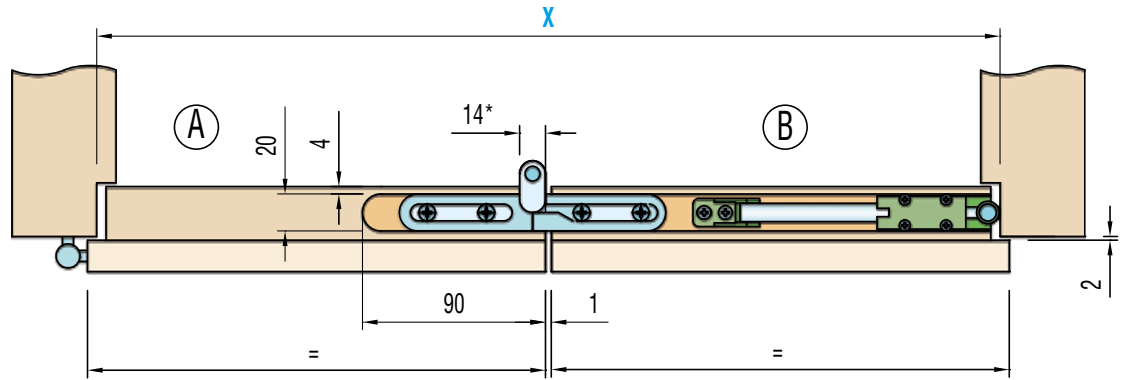

\* LE CERNIERE INFERIORI E SUPERIORI ART.0129/0130 DEVONO ESSERE MONTATE DECENTRATE RISPETTO LA MEZZERIA DELLA PORTA (VEDI QUOTA 14mm)

\* FIT THE BOTTOM AND TOP HINGES ART.0129/0130 OUT OF THE CENTRE LINE OF THE DOOR (SEE DIM 14mm)



### Schema di montaggio / Assembling

Fissare il binario allo stipite con la guida ART. 0148 già inserito.  
 Unire le due ante della porta con le cerniere centrali ART. 0129-0130.  
 Fissare la porta allo stipite con le cerniere laterali.

*Fit the guide ART. 0148 to the profile, then fit the profile to the doorpost.  
 Join the two panels to the central hinges ART. 0129-0130.  
 Fit the door to the doorpost with the side hinges.*

<b>0129</b>	Cerniera con molla per porta spessore 40 mm. Hinge with spring for door thickness 40 mm.
<b>0130</b>	Cerniera senza molla per porta spessore 40 mm. Hinge without spring for door thickness 40 mm.
<b>0148</b>	Guida con braccio telescopico Guide with telescopic arm
<b>0149Z</b>	Battuta di fine corsa End-of-run plug
<b>0140</b>	Profilo alluminio superiore Upper aluminium profile

